

PLEASE SIGN TO APPROVE SEAL LOCATION OF FLEX CIRCUIT

SIGNATURE: _____ DATE: _____

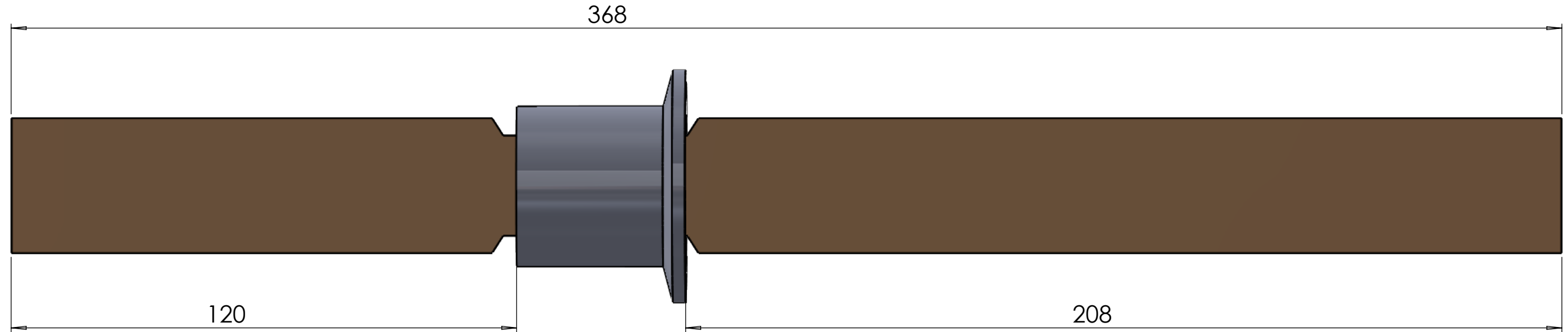

NOTES:

1. DRAWING IS FOR FABRICATION REFERENCE
2. KF40 FLANGE 304 STAINLESS STEEL

<p>The information given herein is based on data believed to be accurate, but BCE makes no expressed or implied warranties as to its accuracy and assumes no liability arising out of its use by others. This information does not constitute a license to use or infringe on any patents</p>	<p>UNLESS OTHERWISE SPECIFIED:</p>	<p>PART. NO. BCE</p>	
	<p>DIMENSIONS ARE IN MM TOLERANCES: FRACTIONAL ± ANGULAR: MACH ± BEND ± TWO PLACE DECIMAL ± .010 THREE PLACE DECIMAL ± .005</p>	<p>TITLE: FLEX CIRCUIT 6200206</p>	
<p>PROPRIETARY AND CONFIDENTIAL THE INFORMATION CONTAINED IN THIS DRAWING IS THE SOLE PROPERTY OF BELILOVE CO. ENGINEERS. ANY REPRODUCTION IN PART OR AS A WHOLE WITHOUT THE WRITTEN PERMISSION OF BELILOVE CO. ENGINEERS IS PROHIBITED.</p>	<p>INTERPRET GEOMETRIC TOLERANCING PER:</p>	<p>SIZE B</p>	<p>DWG. NO. BCE10897</p>
	<p>MATERIAL SEE DWG</p>		<p>REV 0</p>
	<p>FINISH N/A</p>		
	<p>DO NOT SCALE DRAWING</p>	<p>SCALE: NTS WEIGHT: N/A SHEET 1 OF 1</p>	