

B

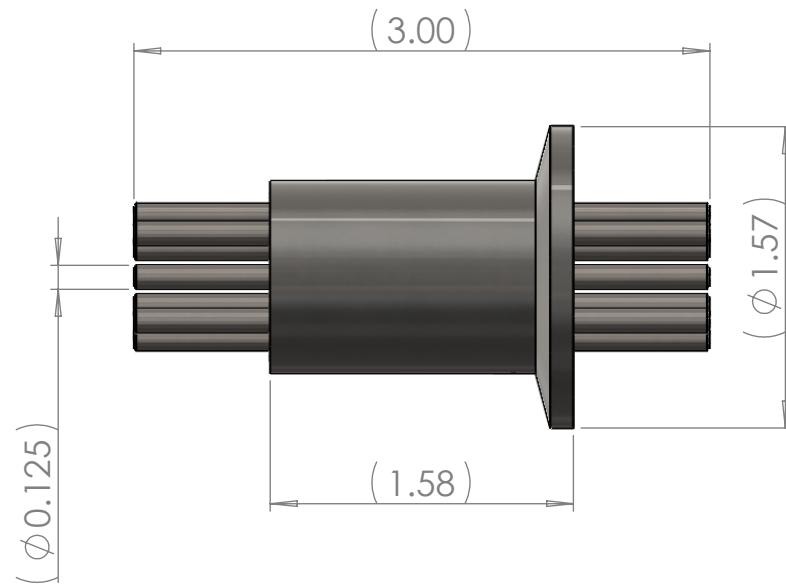
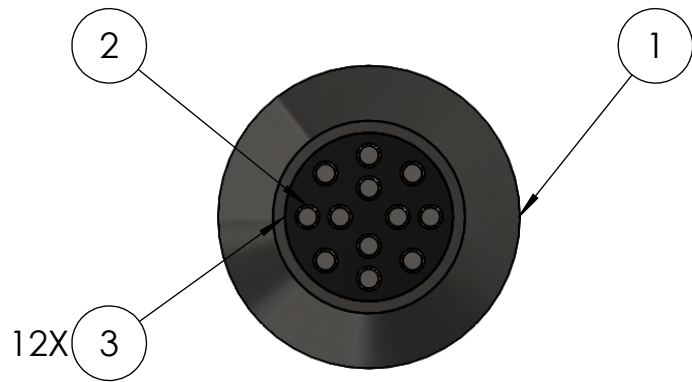

B

ITEM NO.	PART NUMBER	DESCRIPTION	QTY.
1	FLQF25100LF	SS304 KF25 FLANGE	1
2	PIN97395A614	31 6SS DOWEL PINS	12
3	/EPOXY	BCE PROPRIETARY BLACK EPOXY	A/N

UNLESS OTHERWISE SPECIFIED:

DIMENSIONS ARE IN INCHES  
 TOLERANCES:  
 FRACTIONAL ±  
 ANGULAR: MACH ± BEND ±  
 TWO PLACE DECIMAL ± .01  
 THREE PLACE DECIMAL ± .005

INTERPRET GEOMETRIC  
TOLERANCING PER:MATERIAL  
SEE BOMFINISH  
N/A

DO NOT SCALE DRAWING



TITLE:

12 PIN ELECTRICAL  
 FEEDTHROUGH

SIZE

A

DWG. NO.

BCE10338

REV

1

SCALE: 1:1

WEIGHT: N/A

SHEET 1 OF 1

**NOTE**

1. THIS DRAWING IS FOR REF. ONLY

A

2

1