

4

3

2

1

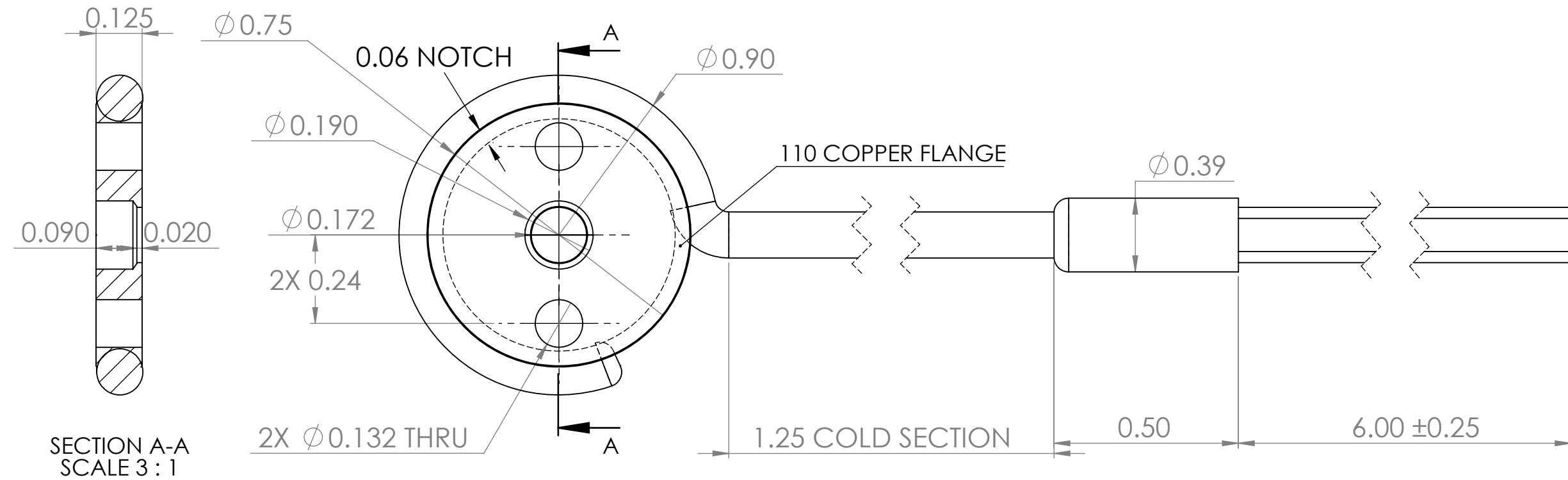
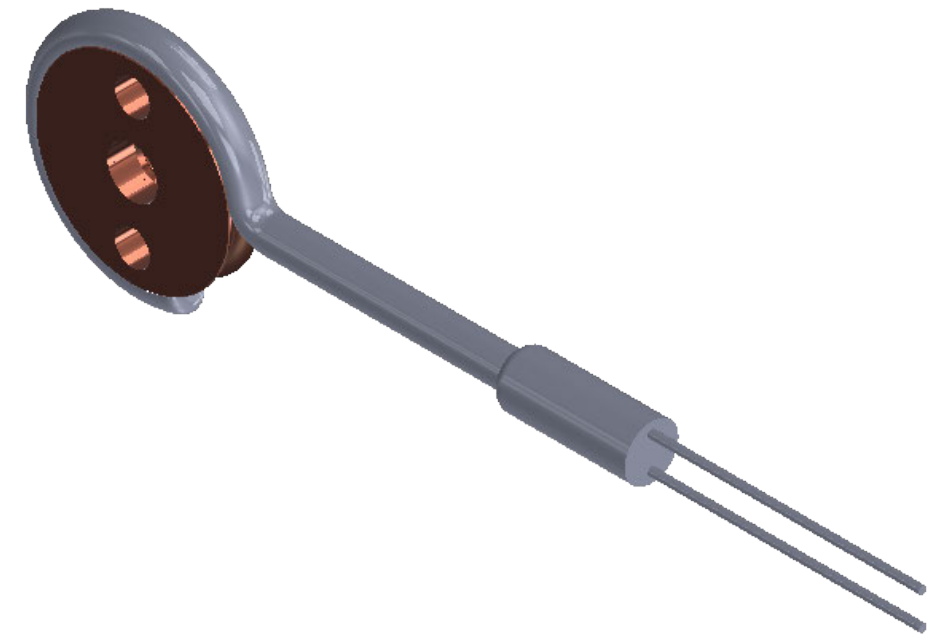

NOTES

1. HEATER SPECS: 25 W, 120 VOLT, 304 SS
2. TOTAL HEATER LENGTH 3.25"
3. ALL SHARP EDGES TO BE REMOVED AND DEBURRED

UNLESS OTHERWISE SPECIFIED:
 DIMENSIONS ARE IN INCHES
 TOLERANCES:
 FRACTIONAL ±1/32
 ANGULAR: MACH ± 1.0 BEND ±2.0
 TWO PLACE DECIMAL ±0.01
 THREE PLACE DECIMAL ±0.005

PROPRIETARY AND CONFIDENTIAL
 THE INFORMATION CONTAINED IN THIS DRAWING IS THE SOLE PROPERTY OF BELILOVE COMPANY ENGINEERS (BCE). ANY REPRODUCTION IN PART OR AS A WHOLE WITHOUT THE WRITTEN PERMISSION OF BELILOVE COMPANY ENGINEERS (BCE) IS PROHIBITED.

INTERPRET GEOMETRIC TOLERANCING PER:
 MATERIAL SEE DWG
 FINISH N/A
 DO NOT SCALE DRAWING



TITLE:
COPPER FLANGE HEATER 25 W 120 V

SIZE	DWG. NO.	REV
B	BCE10683	-
SCALE: NTS		SHEET 1 OF 1

4

3

2

1

B

B

A

A