

B

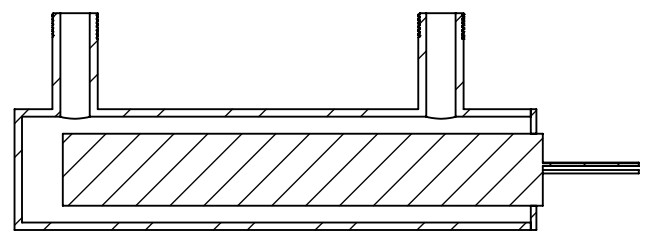

SECTION B-B

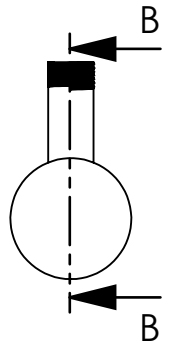
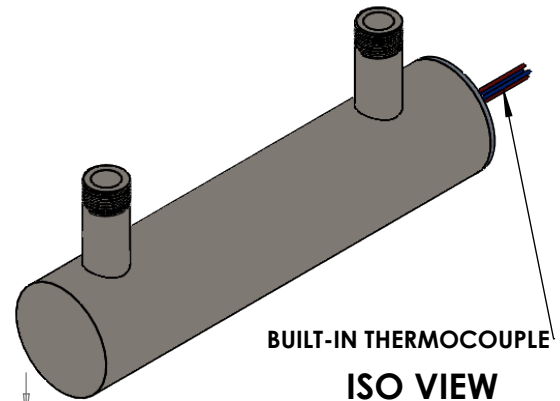

BUILT-IN THERMOCOUPLE  
**ISO VIEW**  
SCALE:NTS

B

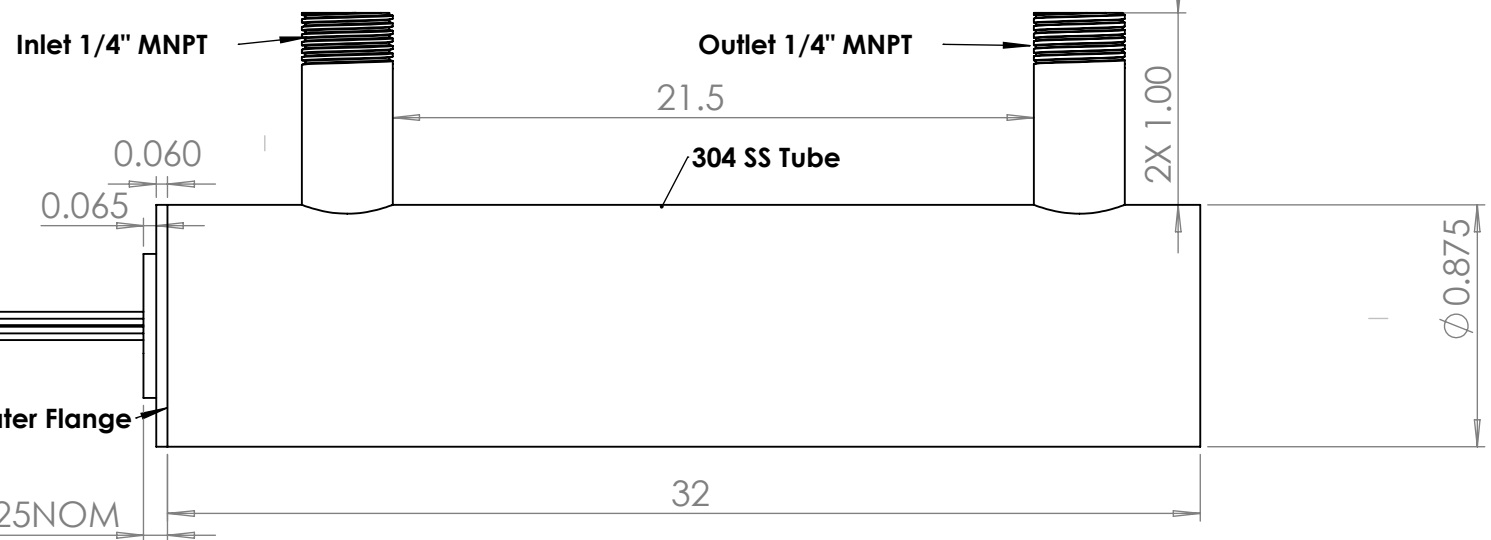

2x Teflon Leads W/ Built in Type K TC, (120")

**NOTES**

1. THIS DRAWING IS FOR REFERENCE ONLY
2. HEATER: 7.5KW (2 Zone 3750W each) (+/-10%), 240V 31.5" INTERNAL LENGTH
3. BUILT-IN TYPE "K" TC
4. MUST NOT POWER WITHOUT LIQUID FLOW
5. STEAM GENERATOR

**PROPRIETARY AND CONFIDENTIAL**  
 THE INFORMATION CONTAINED IN THIS DRAWING IS THE SOLE PROPERTY OF BCE INC. ANY REPRODUCTION IN PART OR AS A WHOLE WITHOUT THE WRITTEN PERMISSION OF BCE INC. IS PROHIBITED.

UNLESS OTHERWISE SPECIFIED:	NAME	DATE
DIMENSIONS ARE IN INCH TOLERANCES: FRACTIONAL ± ANGULAR: MACH ± BEND ± TWO PLACE DECIMAL ± .01 THREE PLACE DECIMAL ± .005	DRAWN A.M	
INTERPRET GEOMETRIC TOLERANCING PER:	CHECKED D.S	
MATERIAL <b>304- SS</b>	ENG APPR.	
FINISH N/A	MFG APPR.	
DO NOT SCALE DRAWING	Q.A.	
	COMMENTS:	



TITLE:  
**SMART FLOW HEATER**  
**7.5 KW/240V**

SIZE <b>A</b>	DWG. NO. <b>BCE10538</b>	REV <b>1</b>
SCALE: NTS	WEIGHT: N/A	SHEET 1 OF 1

A

A

2

1